

# SONY®

NTSC/PAL

Color Video Cameras

## SSC-DC174

## SSC-DC172P

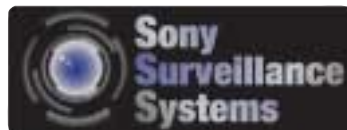

Lens is optional.



## Sony SSC-DC174/DC172P Color Video Cameras - the Practical and Cost-Effective Surveillance Solution

Sony introduces new additions to its line of surveillance video cameras – the SSC-DC174/DC172P\*. These cameras incorporate a 1/3-type IT Super HAD™ CCD and Sony Digital Signal Processing (DSP) technology to achieve high picture quality and remarkable sensitivity with a sound-to-noise (S/N) ratio of more than 50 dB. Providing various convenient features such as Turbo AGC, Auto Tracing White (ATW) Balance, Back-Light Compensation and more, the SSC-DC174/DC172P offers an ideal solution for a wide range of surveillance applications in locations ranging from banks and retail stores to warehouses – at an affordable price.

\*The SSC-DC174 is intended for use in NTSC areas, the SSC-DC172P is for use in PAL areas.

## FEATURES

### High Picture Quality

---

The SSC-DC174/172P cameras incorporate a 1/3-type IT Super HAD™ CCD that achieves a horizontal resolution of 330 TV lines and a minimum illumination of 0.6 lx at F1.2 (50 IRE).

### DSP Technology

---

These cameras incorporate Sony DSP technology for powerful picture contrast control. Providing outstanding stability over long periods of time and reliability levels unattainable with analog signal processors, the SSC-DC174/172P cameras capture superb images under various lighting conditions.

### Compact and Stylish Design

---

With dimensions of 60 (W) x 54 (H) x 120 (D) mm and weighing only 355 grams, these compact cameras can easily be installed in places where space is limited and installation was previously difficult for larger cameras. Their stylish and unobtrusive, metallic-silver design will complement any decor.

### Turbo AGC

---

The SSC-DC174/172P cameras are equipped with an advanced Turbo AGC function. This allows users to boost camera gain to 24 dB, enabling viewers of the image to distinguish the subject more easily - even if it is shot in low light. The AGC mode is switchable between OFF and TURBO.

### Wide Auto Tracing White (ATW) Range

---

ATW is a feature that automatically adjusts the camera's white balance to adapt to changing light conditions. The SSC-DC174/172P cameras provide an extremely wide ATW range of 2,000 K to 10,000 K, allowing adjustment-free operation under a variety of light conditions. This ensures that a precise color image is always obtained.

## Back-Light Compensation (BLC)

Unwanted backlighting can often cause the subject matter of an image to be cast into shadow. The BLC function incorporated in these cameras will automatically compensate for such conditions and allow the subject to be easily visible with an improved level of object recognition.

## CS-Mount

These cameras are equipped with a CS-lens mount, which provides compatibility with industry-standard CS-mount lenses. Precise back focus is easily attained.

## CCD Iris

This function allows the use of a manual iris lens instead of a more costly automatic iris lens. As the scene illumination level increases, these cameras respond by automatically reducing the exposure time of the photo sensors. This is achieved by changing the electronic shutter speed of the CCD, in the range of 1/60 (SSC-DC174) / 1/50 (SSC-DC172P) to 1/100,000 seconds.

## Tripod Screw Holes

Installing and setting up your camera is simple. It includes tripod screw holes at the top and bottom of its body, so no special tripod adaptors are required.

# SYSTEM CONFIGURATIONS

## Single Camera Operation

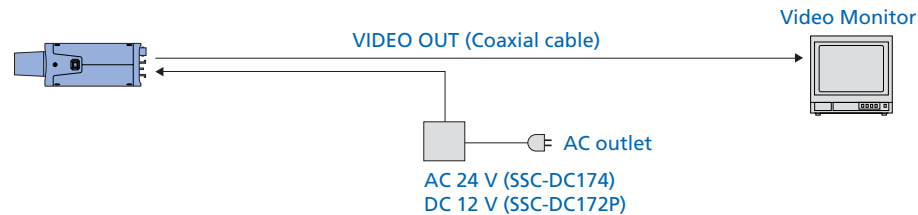

## Multi Camera Operation with Line Lock Operation\*

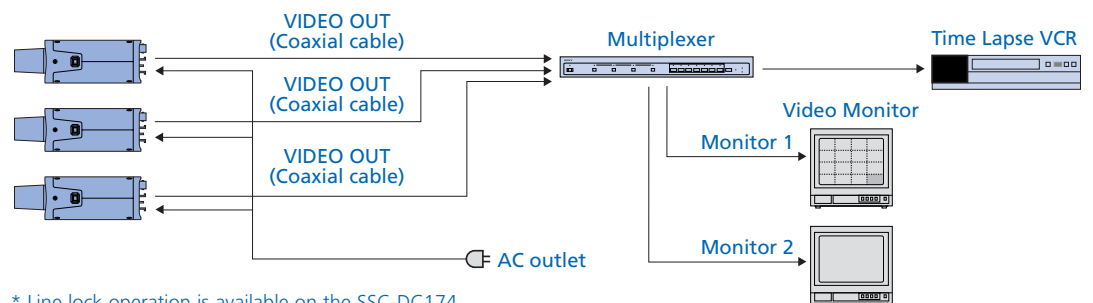

\* Line lock operation is available on the SSC-DC174.

## Multi Camera Operation over LAN

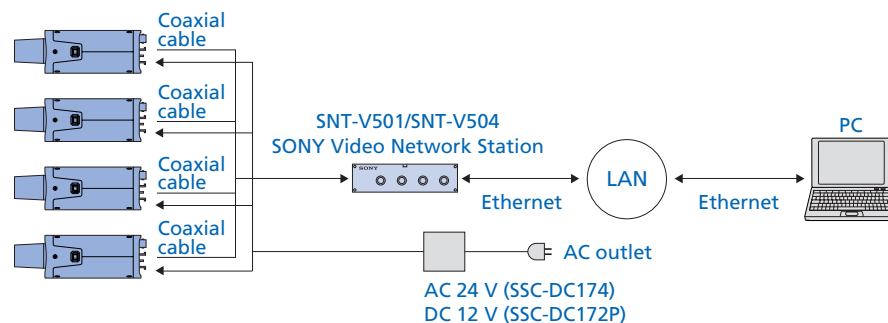

# SPECIFICATIONS

	SSC-DC174	SSC-DC172P
Image device	1/3 type Interline Transfer CCD	
Picture elements (H x V)	510 x 492 (NTSC)	500 x 582 (PAL)
Sensing area	1/3 type format (4.8 x 3.6 mm)	
Signal system	NTSC standard	PAL standard
Sync. System	LL	Internal
Horizontal resolution	330 TV lines	
Lens mount	CS	
Minimum illumination	0.6 lx at F1.2 (50 IRE, AGC ON, Turbo mode)	
AGC	TURBO/OFF switchable	
CCD IRIS	ON/OFF switchable (1/60 to 1/100,000 s)	ON/OFF switchable (1/50 to 1/100,000 s)
White Balance (WB)	Auto White Balance (ATW)	
Back-Light Compensation (BLC)	ON/OFF switchable	
S/N ratio	More than 50 dB (AGC OFF, WEIGHT ON)	
Video out	BNC, 1.0 Vp-p, 75 Ω, sync negative	
Auto iris lens	DC servo	
Operating temperature	-10°C to 50°C (14°F to 122°F)	
Storage temperature	-40°C to 60°C (-40°F to 140°F)	
Power requirements	AC 24V ±10%, 60 Hz	DC 12 V ±10%
Power consumption	3.4 W	3.0 W
Mass	355 g (12 oz)	
Dimensions (W x H x D)	60 x 54 x 120 mm (2 3/8 x 2 1/4 x 4 3/4 inches)	
Supplied Accessories	Lens mount cap (x 1), Operating instructions (x 1)	

## Rear View

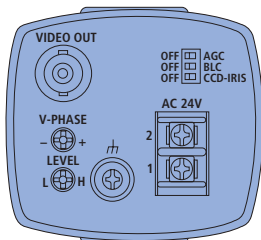

SSC-DC174

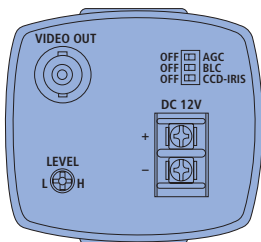

SSC-DC172P

## Dimensions

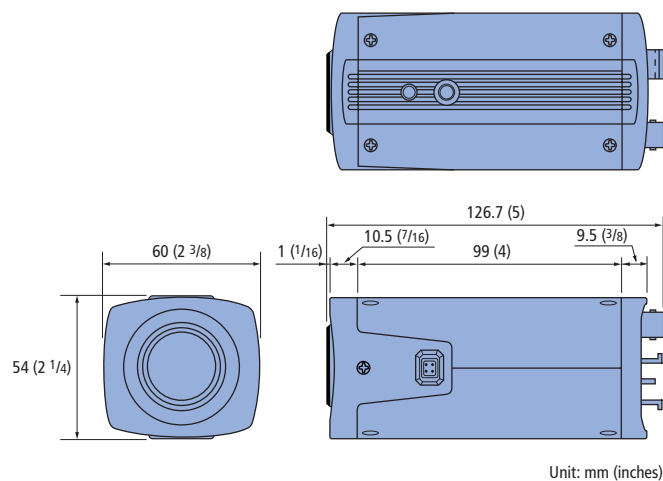

## Distributed by

©2004 Sony Corporation. All rights reserved.  
 Reproduction in whole or in part without written permission is prohibited.  
 Design, features and specifications are subject to change without notice.  
 All non-metric weights and measures are approximate.  
 Sony is a registered trademark of Sony Corporation.  
 Super HAD is a trademark of Sony Corporation.